



HONG KONG PIEZO CO. LTD.
香港功能陶瓷有限公司

Specification

Piezoceramic for Ultrasonic Welding

Part No: HKP-WT-P8228105

Unit: mm

Dimension : $\Phi 28 \times \Phi 10 \times 5\text{mm}$

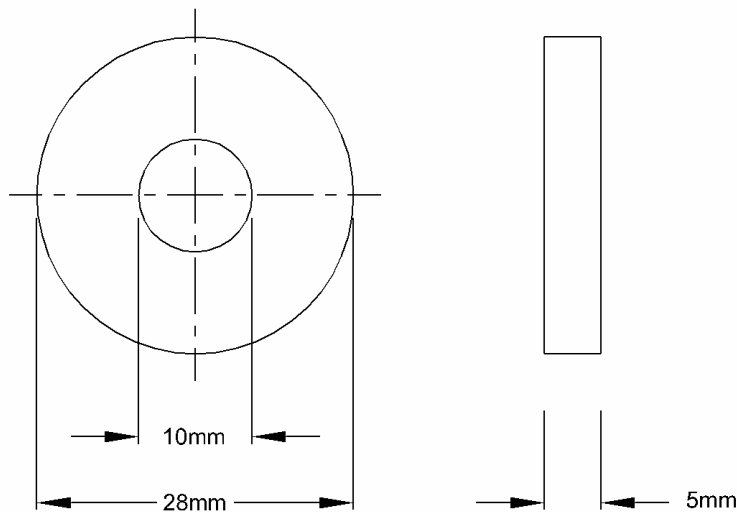

Electrical Characteristics:

- | | |
|----------------|------------------------------------|
| 1. Frequency | : 59 KHz \pm 5% |
| 2. Capacitance | : 1100 pf \pm 5% |
| 3. tg δ | : 30×10^{-4} |
| 4. Kp | : 0.58 |
| 5. d33 | : $>320 \times 10^{-12}\text{C/N}$ |

Flat 15, 9/F, Block A, Veristrong Industrial Centre, 34-36 Au Pui Wan Street, Fo Tan, N.T., Hong Kong.

香港火炭坳背灣街 34-36 號豐盛工業中心 A 座 9 字樓 15 室

Tel: (852) 2694 1029 Fax: (852) 2690 3635

Website: <http://www.piezo.com.hk> Email: info@hkpiezo.com